

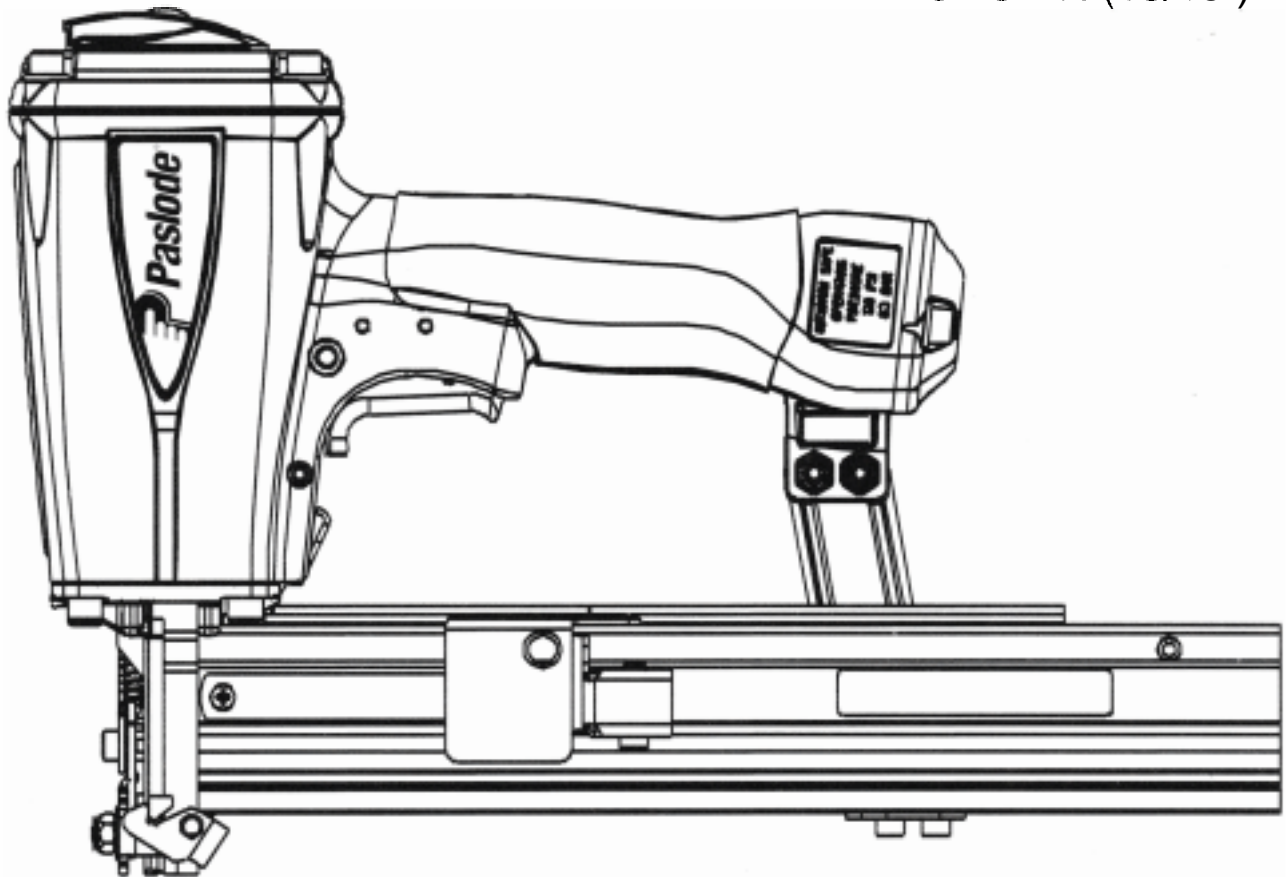

INSULATION SHEATHING STAPLER

MODEL S200 W16

WIDECROWN (15/16")



TOOL SCHEMATIC AND PARTS

IMPORTANT!
DO NOT DESTROY

Always refer to safety and operating manuals, #403606, #405218 and #405222 for detailed information on this tool. It is the customer's responsibility to have all operators and service personnel read and understand this information.

S200 W16
501265

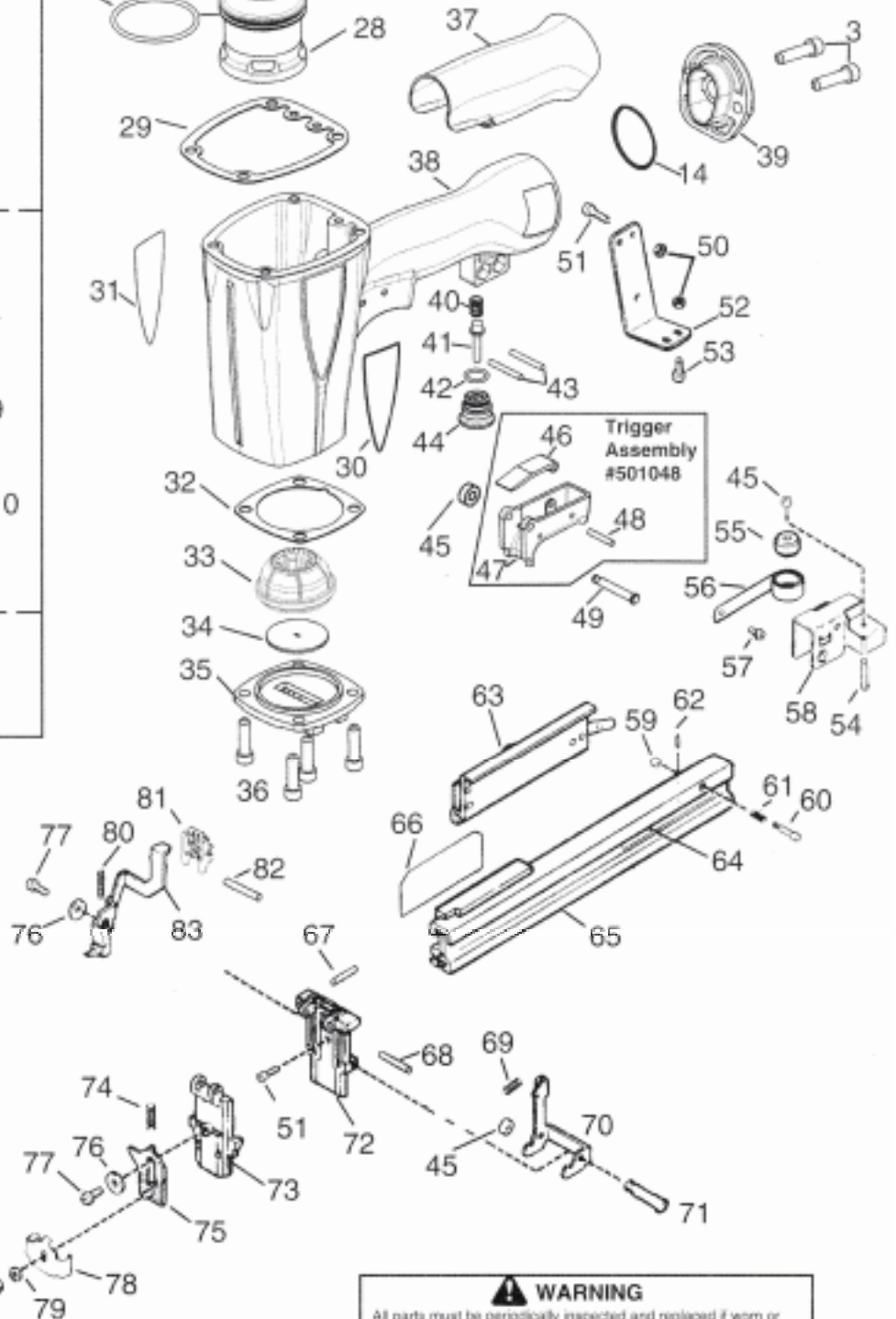
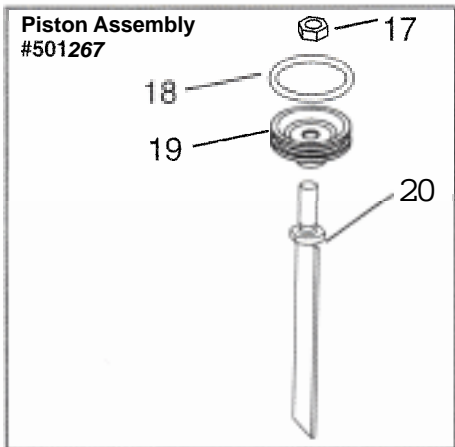
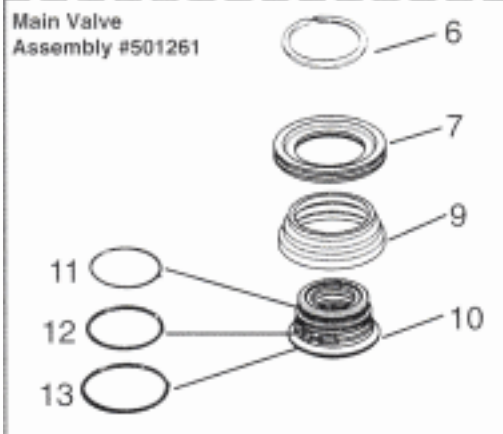
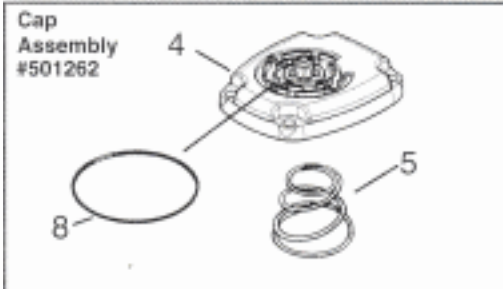
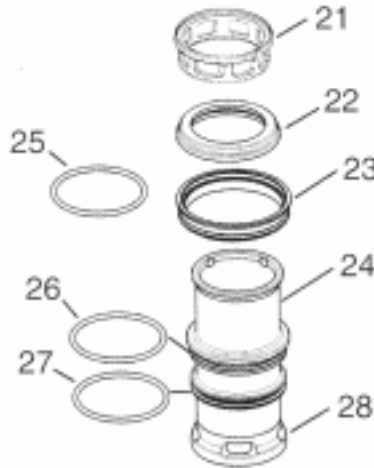
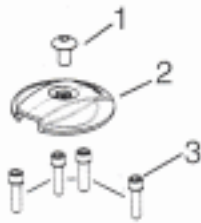

WARNING
All parts must be periodically inspected and replaced if worn or broken. Failure to do this can affect the tool's operation and present a safety hazard.

PARTS LEGEND

S200 W16,501265

1	501043	1	T.H.S.C.S. 1/4-20 x 112"	43	026133	2	Roll Pin 118 x 1
2	500956	1	Cap Diffuser	44	401958	1	Valve Body
3	501299	6	S.H.C.S. 1/4-20 x 1"	45	402668	3	Retaining Washer
4	501254	1	Cap	46	501008	1	Trigger Lever
5	402717	1	Conical Spring	47	501010	1	Trigger
*6	404230	1	Retaining Ring	48	501009	1	Roll Pin
7	501250	1	Upper Valve Piston	49	402669	1	Trigger Pin
*8	091542	1	O-Ring	50	092037	5	Locknut
9	404054	1	Seal, Main Valve	▲ 51	004502	4	S.H.C.S. 10-32 x 518"
10	404056	1	Lower Valve Piston	52	402781	1	Rail Bracket
*11	090927	1	O-Ring, Main Valve	A 53	004224	2	S.H.C.S.10-32 x 3/8"
*12	092775	1	O-Ring, Main Valve	54	402743	1	Pin Negator Drum
*13	092773	1	O-Ring, Main Valve	55	091534	1	Drum, Negator
*14	404256	2	O-Ring	*56	091532	1	Negator
15	500954	1	Post, Main Valve	▲ 57	091568	1	Bd. Head Screw 6-32 x 114"
16	015660	1	S.H.C.S. 10-24 x 112"	58	402760	1	Follower
17	403582	1	Driver Blade Nut	59	402486	1	Retaining Washer
18	405430	1	O-Ring, Piston	60	402758	1	Latch Follower Button
19	501252	1	Piston	61	402759	1	Spring Follower Latch
*20	404182	1	Driver Blade	62	402740	1	Roll Pin 3/32 x 7/16
21	501322	1	Sleeve Retainer	63	402780	1	Pivot Rail Cover Assembly
22	402725	1	Seal Sleeve	64	501291	1	Nameplate
23	405243	1	Flange Sleeve	65	404849	1	Rail & Rail Cover Assembly
24	501251	1	Sleeve	**66	500459	1	Warning Label
*25	402728	1	O-Ring, Sleeve	67	404698	2	Roll Pin Assembly
*26	091966	1	O-Ring, Sleeve	68	402730	1	Pivot Pin Front Guide
*27	500369	2	O-Ring, Sleeve	69	405079	1	Spring Front Guide Latch
28	501227	1	Bumper Retainer	70	501208	1	Latch Guide -
29	500975	1	Gasket Cap	71	501209	1	Latch Pin
30	501140	1	Logo Housing Left	72	501206	1	Back Plate
31	501141	1	Logo Housing Right	73	501212	1	Front Guide
32	402708	1	Gasket Nose Flange	*74	402734	1	Spring W.C.E.
33	501229	1	Bumper	75	402763	1	Upper W.C.E.
34	402754	1	Seal Driver Blade	76	402629	2	Hardened Washer
35	402706	1	Flange Nose	77	403716	2	S.H.C.S. 10-32 x 5/16"
36	091545	4	S.H.C.S. 1/4-20 x 7/8"	78	402608	1	Lower W.C.E.
37	501023	1	Grip Handle	79	402736	1	Flat Washer #10
38	500957	1	Housing	*80	402738	1	Spring
A 39	500963	1	End Plug	81	501320	1	Guide Block
40	097748	1	Spring Valve Pin	82	071297	1	Roll Pin 118 x 1-1/8"
41	097746	1	Valve Pin	83	501244	1	Intermediate W.C.E.
*42	092174	1	O-Ring, Valve Body				

* Denotes normal wear items.

** Make sure warning label (500459) is properly affixed. Replace if necessary. Label available at no charge through the Service Dept.

▲ Apply Loctite 242 (Blue) Part No. 093500

→ Denotes new change.

Fastener sizes:

Length: 3/4" to 2"

Gauge & Crown: 16 ga. 15/16 Crown

AIR CONSUMPTION CHART

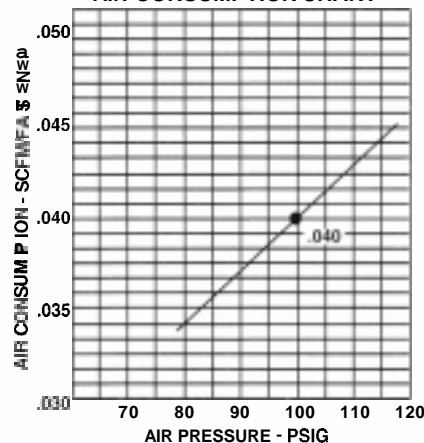

ACCESSORIES

Sequential Operating Kit
 This special attachment is designed for sequential operation (stops "contact" firing). The operator must depress and hold the work contacting element against the worksurface before pulling the trigger. This sequence must be repeated each time the tool drives a fastener.



Part No. 501039

Remote Fire Valve
 This valve via a positive air signal allows a machine mounted tool to be operated from an automatic air valve or foot pedal system.

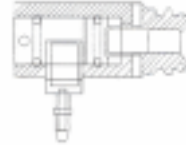

Part No. 1X0713

Safety Glasses

Clear



Part No. 401382

Belt Hook

Attaches to tool enabling you to carry tool on belt holder.

Part No. 500955

Adjustable Foam Contacting Element

Part No. 402997

Rear Activating Contacting Element

Part No. 1x1026

Trigger Valve Repair Kit

This kit repairs all trigger valve air leaks.

Part No. 219224

Lubricants and Loctite

Lubricant 1 lb.

Part No. 403734

Lubricant 5 gram tubes

Part No. 219188

Loctite 242 (Blue) 1 oz.

Part No. 093500

Lubricating Oil 16 oz.

Part No. 403720

Lubricating Oil 8 oz. with Antifreeze

Part No. 219090

Tool Cleaner

Ideal cleaner for all Paslode tools.

Part No. 219348

SAFETY INSTRUCTIONS

WEAR EYE AND HEARING PROTECTION

DO NOT EXCEED MAXIMUM
 RECOMMENDED AIR PRESSURE



Always wear hearing protection and eye protection devices, including side shields when operating or working in the vicinity of a tool.



Operate the tool using only the recommended air pressure. Do not exceed the maximum air pressure marked on the tool. Be sure the air pressure gauge is operating properly and check it at least twice a day.

Never use any bottled air or gases such as oxygen to operate the tool since they could cause the tool to explode.



An Illinois Tool Works Company
 155 Harlem Avenue
 Glenview, IL 60025