

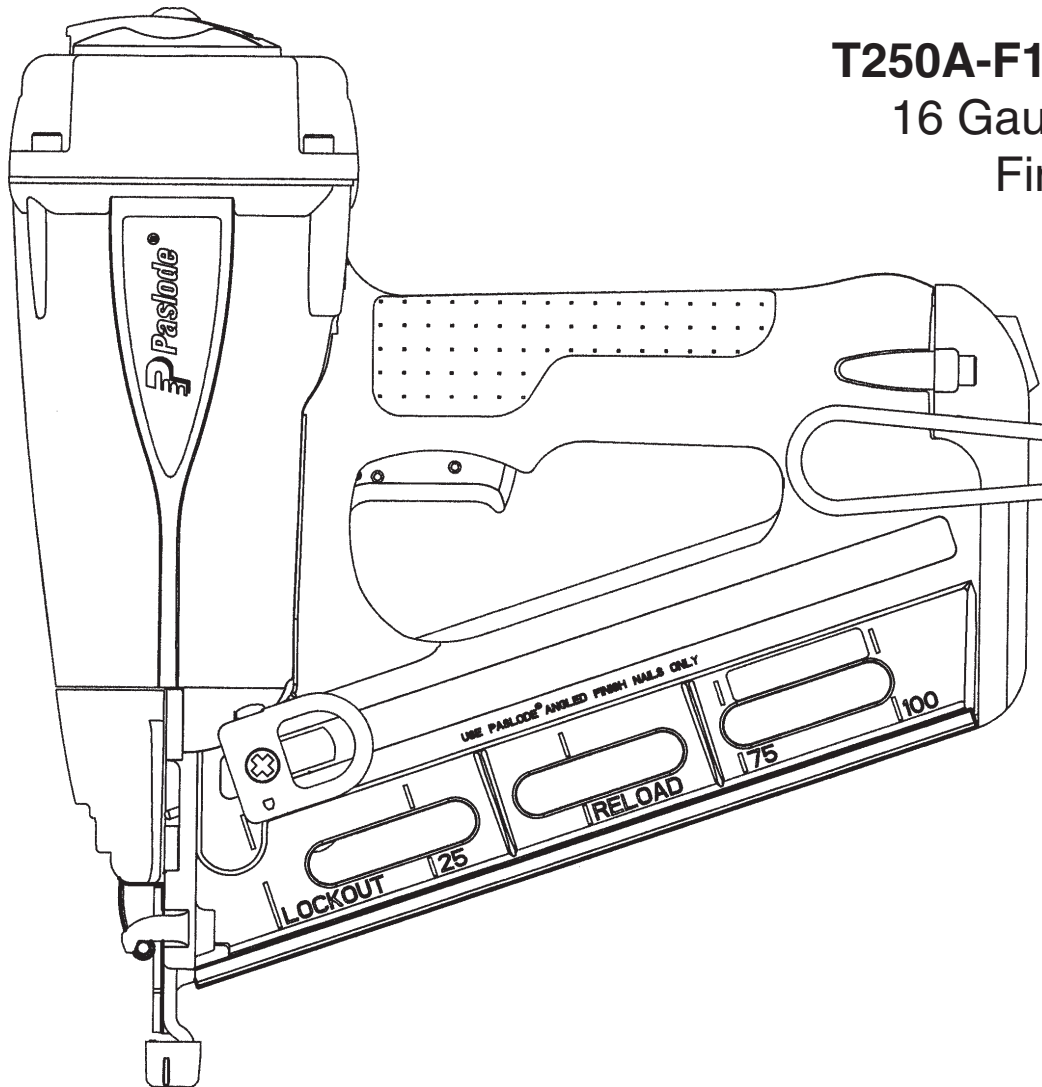

**T250A-F16, P94225**  
16 Gauge Angled  
Finish Nailer



**IMPORTANT!**  
DO NOT DESTROY

It is the customer's responsibility to have all operators and service personnel read and understand this manual.

**OPERATING MANUAL AND  
SCHEMATIC**

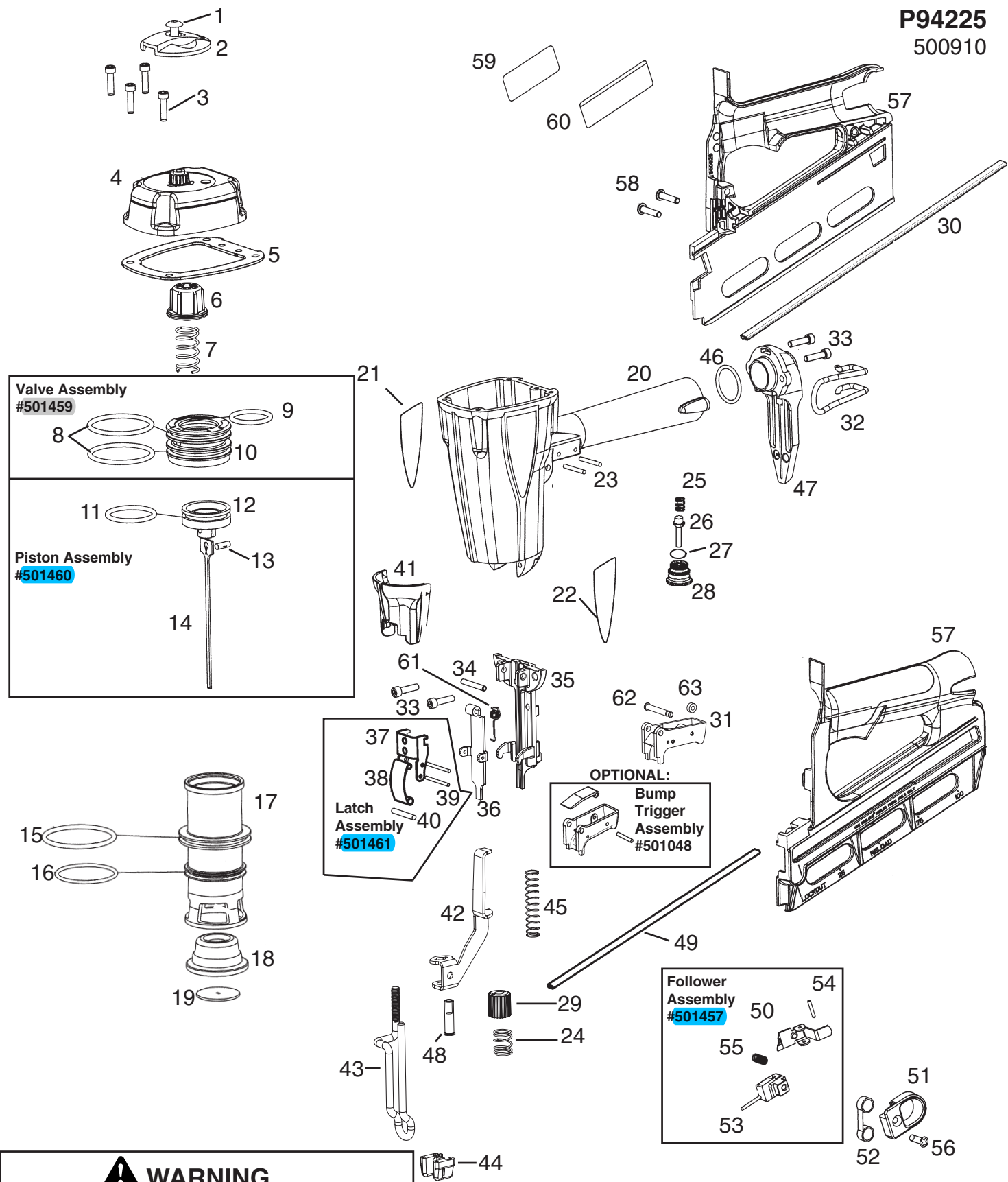

**Valve Assembly**  
 #501459

8 9 10

---

**Piston Assembly**  
 #501460

11 12 13 14

**Latch Assembly**  
 #501461

37 38 39 40

**OPTIONAL:**  
 Bump Trigger Assembly  
 #501048

**Follower Assembly**  
 #501457

50 51 52 53 54 55

**⚠ WARNING**

All parts must be periodically inspected and replaced if worn or broken. Failure to do this can affect the tool's operation and present a safety hazard.

**PARTS LEGEND**

**T250A-F16, P94225, 500910**

1	501043	1	T.H.S.C.S. 1/4-20 x 1/2	32	500940	1	Wire Belt Hook
2	500921	1	Deflector	33	501324	4	S.H.C.S. 10-24 x 3/4
3	501332	4	S.H.C.S. 10x24 x 7/8	34	501316	1	Pin Dowel
4	500909	1	Cap	35	501301	1	Nose
→*5	500927	1	Gasket	36	500918	1	Front Plate
6	500913	1	Piston Stop	37	500924	1	Latch Clamp Spring
7	501288	1	Spring, Main Valve	38	500923	1	Clamp Spring
*8	091023	2	O -Ring	39	404659	2	Roll Pin
*9	095406	1	O -Ring	40	402730	1	Pin
10	501277	1	Main Valve Assembly	41	500939	1	Quick Clear Cover
*11	405430	1	O -Ring	42	501754	1	Upper W.C.E.
12	500911	1	Piston	43	501753	1	Lower W.C.E.
13	401130	1	Driv Lok Pin	*44	500936	1	No-Mar Tip
*14	500920	1	Driver Blade	*45	501414	1	Spring, W.C.E.
*15	091863	1	O -Ring	*46	402963	1	O -Ring
*16	500369	1	O -Ring	47	500928	1	End Plug
17	500907	1	Sleeve	48	501756	1	Pin
→*18	500917	1	Bumper	49	501362	1	Rail, Magazine
*19	501404	1	Blade Seal	50	500933	1	Follower
20	500908	1	Housing	51	501150	1	Pull Back Lever
21	501141	1	Label, Logo R	*52	500944	1	Negator Spring
22	501140	1	Label, Logo L	53	501148	1	Follower Core Assembly
23	026133	2	Roll Pin	54	501225	1	Follower Pin
24	501757	1	Spring	55	500934	1	Spring, Follower
25	097748	1	Spring	56	501224	1	Screw, #8-16 x 5/8 Plastite
26	097746	1	Pin Valve	57	501458	1	Right & Left Handle Kit
*27	092174	1	O -Ring	58	501223	2	Screw, #8-16 x 7/8 Plastite
28	401958	1	Valve Body	**59	501311	1	Nameplate
29	501755	1	Adjustment Knob	60	501302	1	Warning Label
30	500937	1	Brad Chanel	61	501398	1	Torsion Spring, Quick Clear
31	501039	1	Sequential Trigger	62	402669	1	Trigger Pin
				63	402668	1	Retaining Ring

\* Denotes Normal Wear Items.

\*\* Make sure Warning Label (501302) is properly affixed. Replace if necessary.

Label available at no charge through the Service Parts Dept.

**AIR CONSUMPTION CHART**

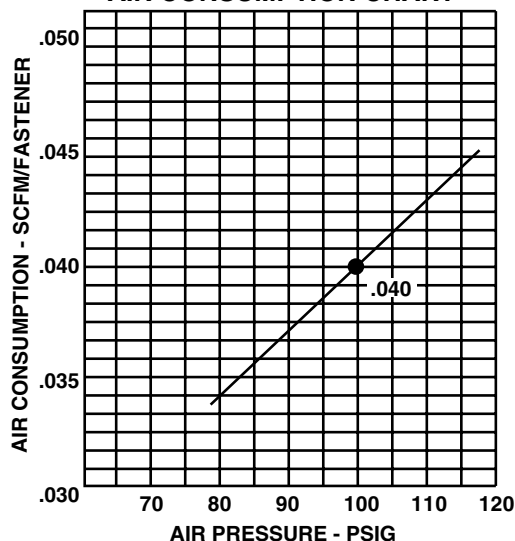

**SAFETY INSTRUCTIONS**

**WEAR EYE AND HEARING PROTECTION**



Always wear hearing protection and eye protection devices, including side shields when operating or working in the vicinity of a tool.



**DO NOT EXCEED MAXIMUM RECOMMENDED AIR PRESSURE**

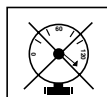

Operate the tool using only the recommended air pressure. Do not exceed the maximum air pressure marked on the tool. Be sure the air pressure gauge is operating properly and check it at least twice a day.

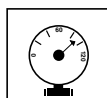

Never use any bottled air or gases such as oxygen to operate the tool since they could cause the tool to explode.

# ACCESSORIES

## Contact Trip Trigger Kit

The T250A-F16 comes with a Sequential Fire Trigger installed on the tool. Using the Sequential Trigger, the user must fully depress the work contact element (w.c.e) before squeezing the trigger and successfully firing the tool. An optional **Contact Trip Trigger**, designed for "bump" or "bounce" firing, is an included accessory. Using the Contact Trip Trigger, the user is able to successively fire fasteners by squeezing and holding the trigger and then "bumping" the w.c.e. along the workpiece. Instructions for changing to the contact trip trigger are included.

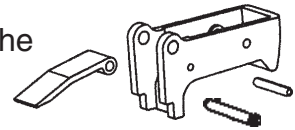

Part No. 501048

---

