

DUO-FAST®

**PNEUMATIC DA65
15G BRADDER
D50100**



ILLUSTRATED PARTS LIST

DUO-FAST
SERVICE KIT
010028

**Duo-Fast DA65
15G Bradder
D50100**

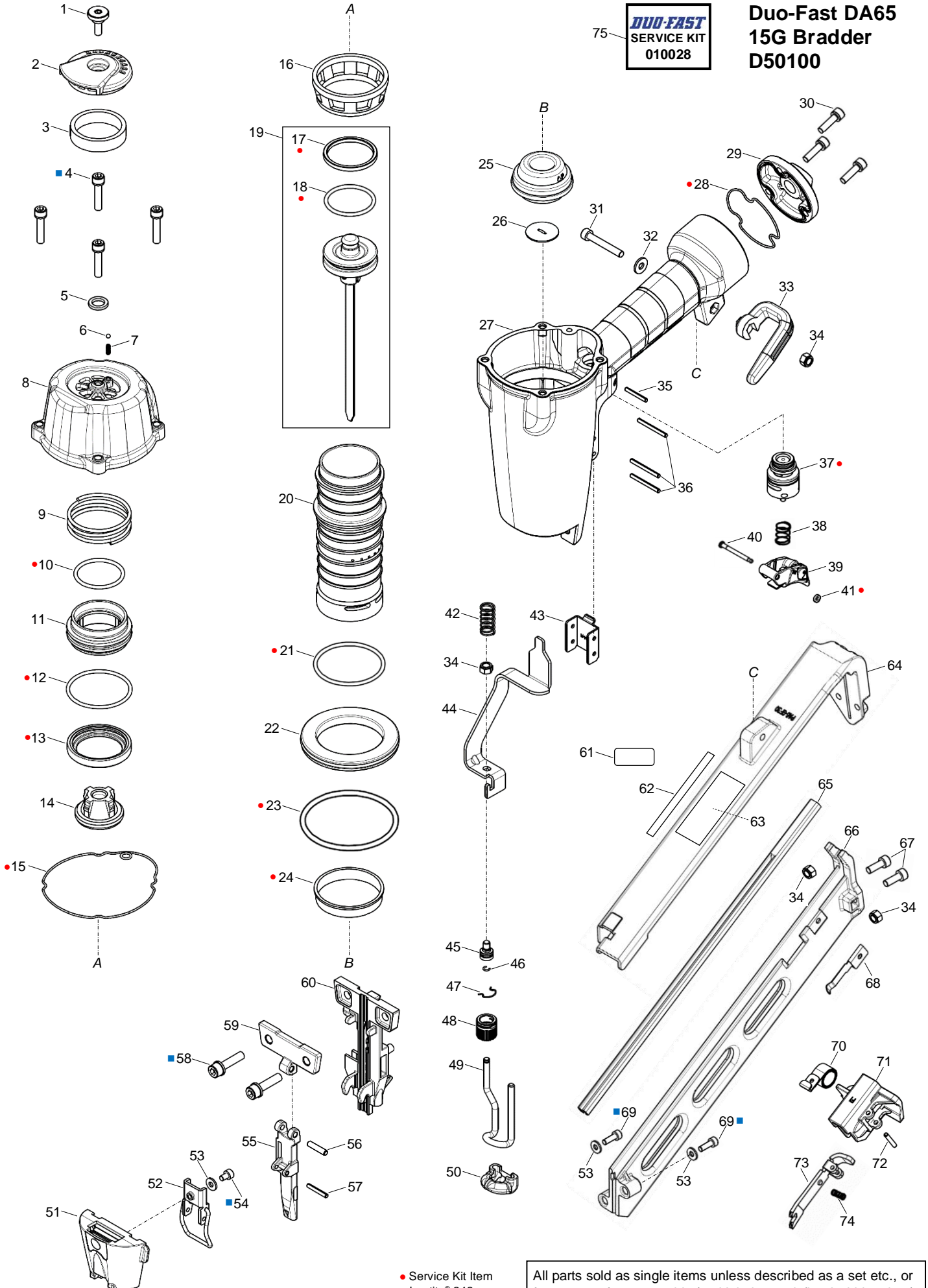

• Service Kit Item
■ Loctite® 242

All parts sold as single items unless described as a set etc., or forms part of an assembly (multiple items defined within a box). A part with no item number is only available in an assembly.

PARTS LEGEND

DUO-FAST DA65 15G ANGLED BRADDER

D50100

1	700001	1 Screw, Deflector	39	501933	1 Trigger Assembly, Duel Mode
2	700003	1 Deflector	40	501934	1 Pin, Trigger Pivot
3	700004	1 Muffler	*● 41	501089	1 Ring, Trigger Pin Retainer
■ 4	700005	4 Screw SEMS	42	501967	1 Spring, Safety
5	700002	1 Washer, Rubber	43	700056	1 Guide, Safety
→ 6	700092	1 Ball	44	700063	1 Lever, Safety
→ 7	700093	1 Spring	45	700060	1 Shaft, Link
8	700006	1 Cap (Paslode Silver)	46	700059	1 E-Ring
9	501904	1 Spring, Main Valve	47	700062	1 C-Clip
*● 10	501905	1 O-Ring	48	700061	1 Wheel, Dod Adjustment
11	700011	1 Piston, Main Valve	49	700057	1 Probe
*● 12	501907	1 O-Ring	50	700064	1 No Mar Tip
*● 13	700012	1 Seal, Cylinder	51	700068	1 Cover Assembly, Latch
14	700013	1 Stopper, Piston	52	700066	1 Latch
*● 15	700007	1 Seal, Cap	53	700080	3 Washer, Flat
16	700014	1 Collar	■ 54	700079	1 Screw SHC
*● 17	700016	1 Ring, Piston	55	700055	1 Nose Plate (Driver Guide)
*● 18	700015	1 O-Ring	56	700054	1 Pin, Nose Plate Pivot
* 19	700017	1 Driver & Piston Assy (RPLD BY 700017A) →	57	700065	1 Pin, Roll
20	700019	1 Cylinder	■ 58	700053	2 Screw SEMS
*● 21	501913	1 O-Ring	59	700052	1 Plate, Set
22	700023	1 Bulkhead	60	700051	1 Nose
*● 23	700024	1 O-Ring	61	700082	2 Label, Logo (Paslode)
*● 24	700020	1 Check Band	62	700084	1 Label, Data Plate (Paslode)
* 25	700021	1 Bumper	63	700083	1 Label, Warning
26	700022	1 Seal, Driver Blade	64	700072	1 Cover, Magazine
27	700042	1 Body Housing Assy (Paslode Silver)	65	700071	1 Channel, Nail
*● 28	700043	1 Seal, Air Inlet Housing	66	700069	1 Magazine
29	700044	1 Housing, Air Inlet	67	700070	2 Bolt SHC
30	700045	3 Screw SEMS	68	700073	1 Plate, Nail Stop
31	700049	1 Bolt SHC	■ 69	700081	2 Bolt SHC
32	700050	1 Washer, Flat	70	700077	1 Spring Assembly, Negator
33	700048	1 Hook, Belt	71	700074	1 Follower Body
34	700067	4 Nut, Nyloc	72	700076	1 Pin, Roll
35	501998	1 Pin, Roll	73	700075	1 Follower (Pusher)
36	501931	3 Pin, Roll	74	700078	1 Spring, Follower
*● 37	501988	1 Valve Assembly, Trigger	75	010028	AR Service Kit
38	501932	1 Spring			

- * Normal Wear Items
 - Included in Service Kit
 - Apply Loctite® 242 (Blue)
 - New Change
- AR As Required

Accessories supplied in carry case*

- 1 x 30ml Oil
- 1 x 3mm Hex Key
- 1 x 4mm Hex Key
- 1 x Safety Glasses

*Carry case non-procurable

Tool supplied with 1/4 NTP Hansen® style air adaptor (installed)
Refer item (42) for Optional Sequential Trigger Assembly



- Use eye protection when cleaning tools.
- Use eye and ear protection when operating/testing tools.
- Use degreaser in a well ventilated area

Use only approved Paslode Compressor Tool Oil PN F27625.
Never use mineral based oils.
Oil tool daily with 2 to 4 drops via air inlet connection.
Heavy usage will require more frequent oiling.

Operating air pressure at the tool inlet: 480-690 kpa (70-100 psi).
Never exceed the maximum stated air pressure.
Regularly check the regulator and pressure gauge operation.

A water/oil trap must be installed on the regulator outlet and drained regularly.

Never use bottled air or gases such as oxygen to operate the tool.



**WARNING: All parts must be periodically inspected and replaced if worn or damaged.
Failure to comply can affect the tool's operation and present a safety hazard.**

Change Notes

Revision 1

Item	Part No.	Item Description	Change	Action/Change Description
6	700092	Ball	Availability	Part introduced
7	700093	Spring		
8	700006	Cap		
*17	700017	Driver & Piston		
27	700042	Body Housing Assy	Design	Replaced by Paslode style (No part number change)
61	700082	Label, Logo		
62	700084	Label, Data Plate		
*34	700039	Trigger Assy, Bump	Manufacturing	Replaced by 39, Duel Mode Trigger Assembly 501933
Opt.	700090	Trigger Assy, Seq.		
Opt.	700091	Spring, Seq. Trigger		
*41	700046	Dust Cover	Availability	Non-Procurable
Acc.	700085	Carry Case		
*25	501921	O-Ring		
*26	501922			
*27	501925			
*28	501926			
*29	501999			
*79	501923			
*80	501924	Plunger Valve		
*81	501927	Spring		
*82	501928	Plunger		
*83	501930	Pin		
*84	501929	Trigger Valve Head		
N/A	Various	Assemblies/Flag Notes		
		Parts/Notes	Parts Legend	Complete layout re-design & re-numbering for clarity. Removed parts no longer available separately Added Service Kit & Kit item flags Updated PN changes Adopted conventional naming Updated Loctite® and item usage