

**NO ANZ SPARE PARTS SUPPORT
FOR REFERENCE ONLY**

**Positive Placement®
Metal Connector Nailer
PF150S-PP
502300**

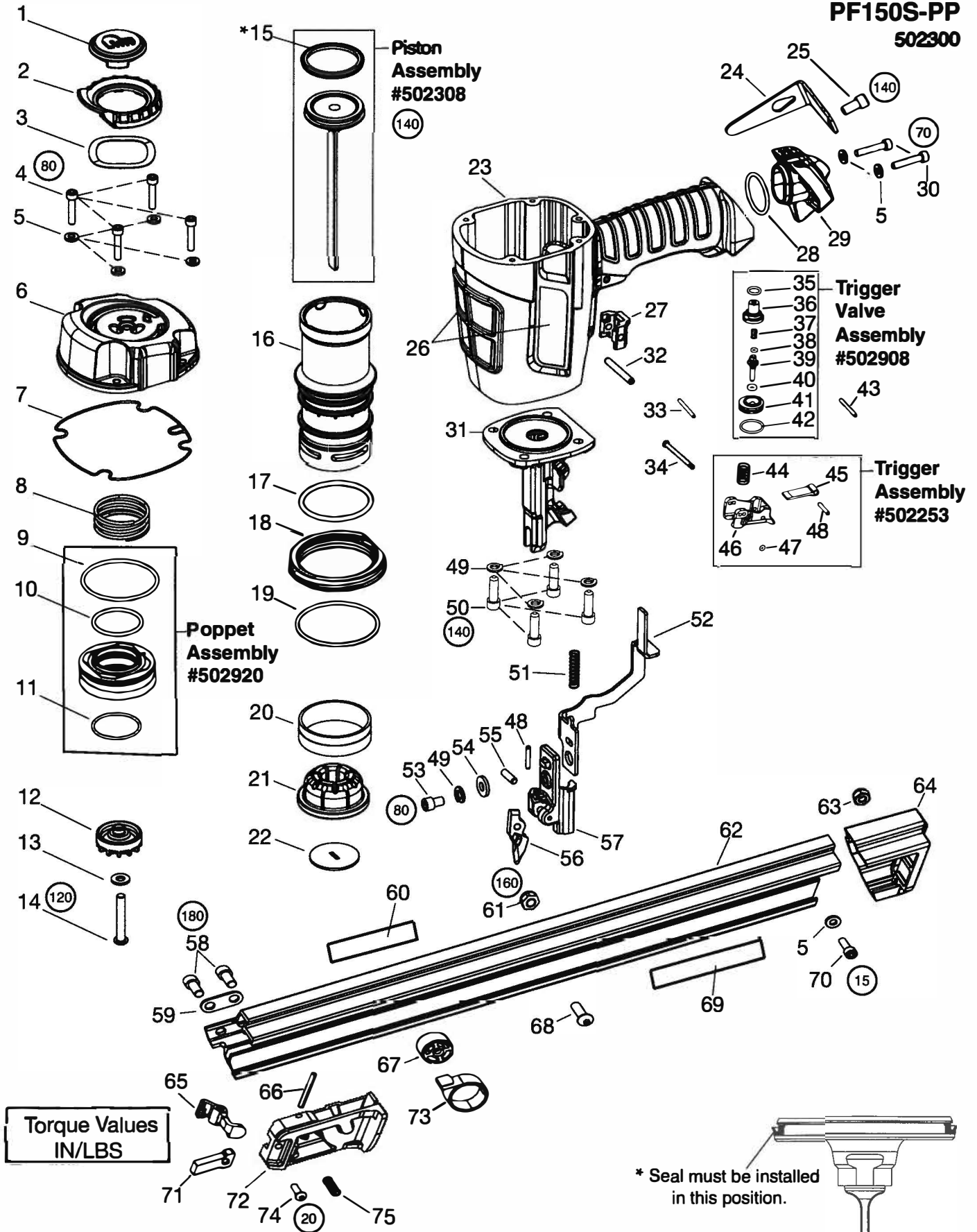

**Torque Values
IN/LBS**



NO ANZ SPARE PARTS SUPPORT - FOR REFERENCE ONLY

Positive Placement[®] PARTS LEGEND Metal Connector Nailer PF150S-PP 502300

1	502330	1	Main Valve Nut	39	502045	1	Valve Pin
2	502304	1	Air Deflector	*40	196345	1	O-Ring
3	502343	1	Wave Washer	41	502043	1	Lower Valve Spool
▲ 4	502339	4	S.H.C.S. #10-24 x 7/8"	*42	092747	1	O-Ring
5	408302	7	Flat Washer	43	403796	1	Roll Pin 1/8"x 1-1/4"
6	502303	1	Cap	44	502060	1	Spring, Trigger
7	502313	1	Gasket, Cap	45	502225	1	Trip Lever
8	360594	1	Spring,	46	502224	1	Trigger, Sequential
* 9	202382	1	O-Ring	*47	502042	1	O-Ring
*10	201806	1	O-Ring	48	091866	2	Roll Pin 1/8" x 3/4"
*11	539676	1	O-Ring	49	002187	5	Lock Washer
*12	502056	1	Exhaust Seal Assembly	▲ 50	091545	4	S.H.C.S. 1/4-20 x 7/8"
13	1011802	1	Washer	*51	502328	1	Spring, W.C.E.
▲ 14	502327	1	B.H.C.S. 1/4-20 x 1-1/2"	52	502321	1	W.C.E. Upper
*15	502311	1	Piston Seal	▲ 53	502337	1	S.H.C.S. 1/4-20 x 3/8"
16	502309	1	Sleeve, Cylinder	54	404800	1	Flat Washer
17	502104	1	O-Ring, Flange	55	502325	1	Probe Pin
*18	502307	1	Flange	*56	502346	1	Probe
*19	192799	1	O-Ring, Flange	57	502320	1	W.C.E., Lower
*20	502310	1	Check Band	▲ 58	502338	2	S.H.C.S. 1/4-28 x 1/2"
*21	502317	1	Bumper	59	502323	1	Magazine Washer
22	500729	1	Blade Seal	** 60	502917	1	Label
23	502302	1	Housing W/Overmolded grip	61	442681	1	Lock Nut
24	502332	1	Rafter Hook	62	502316	1	Magazine Assembly
25	502345	1	S.H.C.S. 5/16-18 x 5/8"	63	092037	1	Lock Nut
*26	502034	1	Label, Housing RIGHT	64	502329	1	End Cap, Magazine
	502035	1	Label, Housing-Left	65	502319	1	Follower Claw
27	502033	1	W.C.E. Guide Block	66	502340	1	Spiral Pin
*28	402963	1	O-Ring, Housing End Plug	67	502025	1	Drum Pin Assembly
29	502305	1	End Plug, Housing	▲ 68	502017	1	B.H.C.S 1/4-20 x 3/4"
▲ 30	502336	2	S.H.C.S. #10-24 x 1"	69	502928	1	Logo Label
31	502306	1	Nose	▲ 70	502347	1	S.H.C.S. 10-32 x 5/8"
32	380931	1	Roll Pin 3/16 x 1-1/2"	71	502335	1	Lockout Bar
33	502333	1	Roll Pin, Trigger 1/8 x 1-1/2"	72	502318	1	Follower Body
34	502324	1	Pin, Trigger	73	502226	1	Negator Spring
*35	197913	1	O-Ring	▲ 74	500627	1	B.H.C.S. 8-32 x 1/2"
36	502044	1	Upper Valve Spool	75	402734	1	Spring, Follower Body
*37	502059	1	Spring, Valve Pin				
*38	1015358	1	O-Ring				

- * Denotes Normal Wear Items
- ** Make sure Warning Label (Part No.502917) is properly affixed. Replace if necessary. Label available at no charge through the Service Department.
- ▲ Apply Loctite[®] 242 (Blue) Part No. 093500
- Apply Loctite[®] 620 (Green) Part No. 401491
- Denotes New Change

▲ WARNING

All parts must be periodically inspected and replaced if worn or broken. Failure to do this can affect the tool's operation and present a safety hazard.

