

MODEL S150-N18
Narrow Crown
STAPLER

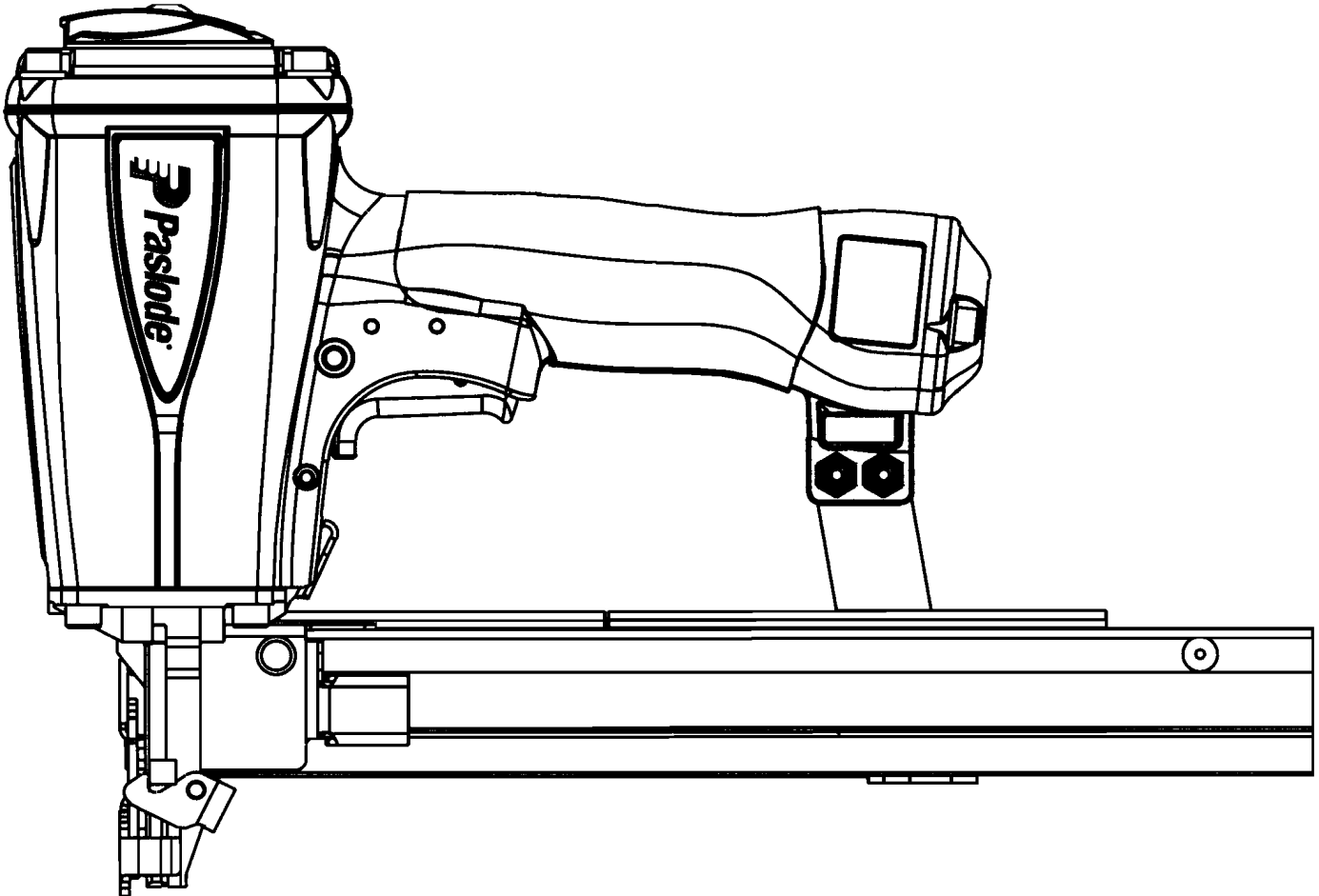

TOOL SCHEMATIC AND PARTS

IMPORTANT!
DO NOT DESTROY

Always refer to safety and operating manuals, #403606, #405218 and #405222 for detailed information on this tool. It is the customer's responsibility to have all operators and service personnel read and understand this information.

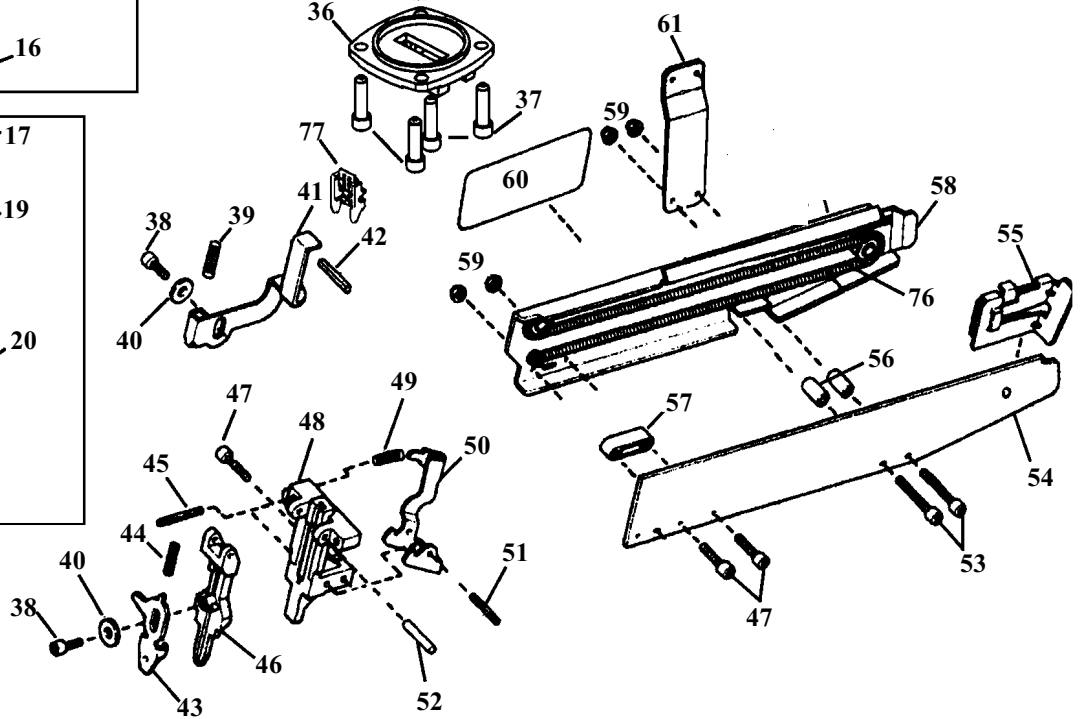
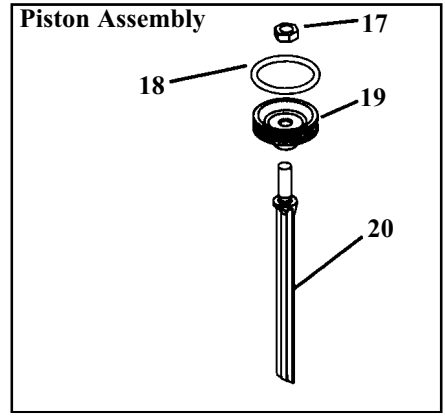
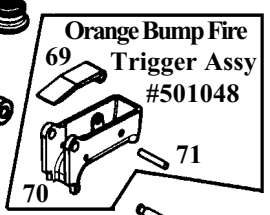
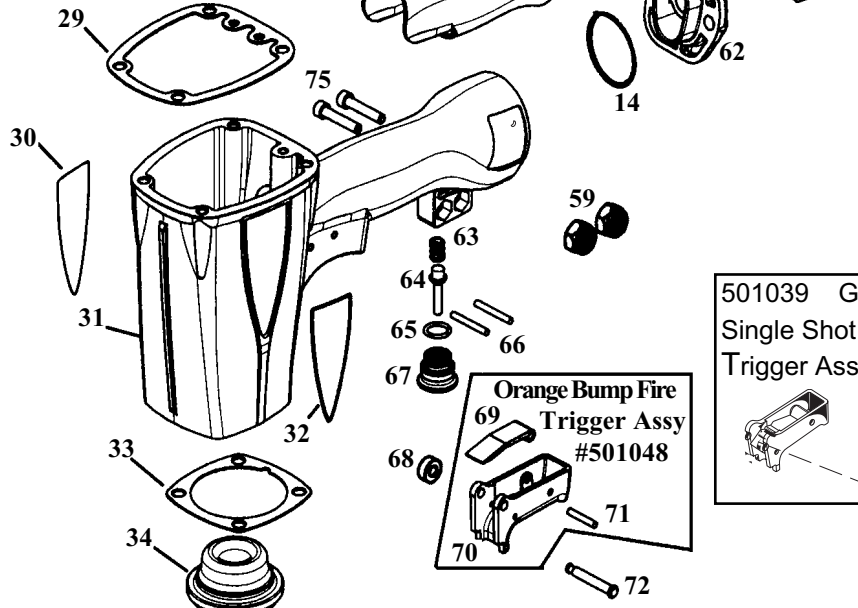
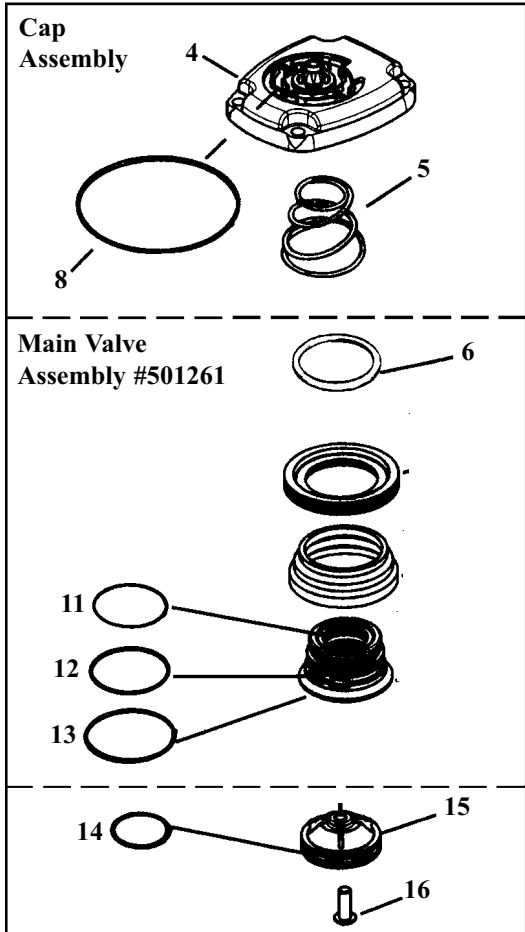
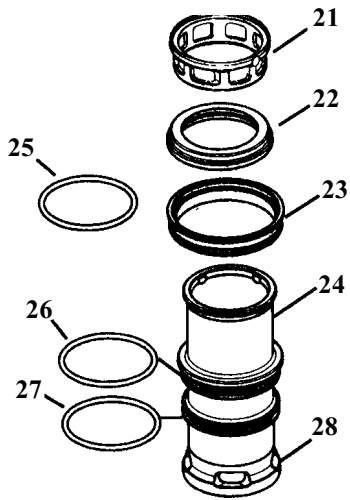
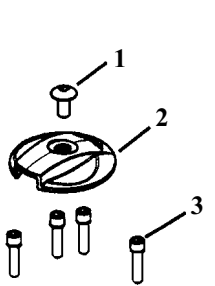

Warning

All parts must be periodically inspected and replaced if worn or broken. Failure to do this can affect the tool's operation and present a safety hazard.

PARTS LEGEND

MACHINE CODE : A10330

S150-N18,501260

1	501043	1	T.H.S.C.S. 1/4-20 X 1/2	40	402629	2	HARDENED WASHER
2	500956	1	CAP DIFFUSER	41	501243	1	INTERMEDIATE W.C.E.
3	501299	6	S.H.C.S. 1/4-20 X 1	42	071297	1	ROLL PIN
4	501254	1	CAP	43	403379	1	W.C.E.
5	402717	1	CONICAL SPRING	44	402734	1	SPRING
6	404230	1	RETAINING RING	45	404698	2	ROLL PIN ASSEMBLY
*8	091542	1	"O" Ring.	46	403214	1	FRONT GUIDE
*11	090927	1	"O" Ring	47	009059	3	S.H.C.S. 10-32 X 3/4
*12	092775	1	"O" Ring, MAIN VALVE.	48	403213	1	BACK PLATE
*13	092773	1	"O" Ring, MAIN VALVE.	49	405079	1	SPRING,FRONT GUIDE LATCH
*14	404256	2	"O" Ring, VALVE POST,END PLUG	50	403215	1	LATCH FRONT GUIDE
15	500954	1	POST MAIN VALVE	51	092178	1	ROLL PIN 5/32 X 1
16	015660	1	S.H.C.S. 10-24 X 1/2	52	402730	1	PIVOT PIN,FRONT GUIDE
17	403582	1	BLADE NUT	53	080326	2	S.H.C.S. 10-32 X 1
*18	405430	1	"O" Ring, PISTON	54	403218	1	RAIL
19	501169	1	PISTON	55	403221	1	FOLLOWER
20	403727	1	DRIVER BLADE	56	403380	2	SPACER,RAIL TO BRACKET
21	501322	1	SLEEVE RETAINER	57	403376	1	SPACER,RAIL COVER
22	402725	1	Seal, Sleeve	58	403753	1	RAIL COVER ASSEMBLY
23	405243	1	FLANGE SLEEVE	59	092037	6	LOCNUT # 10-32
24	501251	1	SLEEVE	**60	500459	1	Warning Label
*25	402728	1	"O" Ring SLEEVE	61	403219	1	RAIL BRACKET
*26	091966	1	"O" Ring SLEEVE	62	500963	1	END PLUG
*27	500369	2	"O" Ring SLEEVE	63	097748	1	SPRING,VALVE PIN
28	501227	1	BUMPER RETAINER	64	097746	1	VALVE PIN
29	500975	1	GASKET CAP	65	092174	1	"O"RING VALVE BODY
30	501140	1	LOGO,HOUSING R	66	026133	2	ROLL PIN 1/8 X 1
31	500957	1	HOUSING	67	401958	1	VALVE BODY
32	501141	1	LOGO,HOUSING L	68	402668	1	RETAINING WASHER
33	402708	1	GASKET, NOSE FLANGE	69	501008	1	LEVER TRIGGER
34	501229	1	BUMPER	70	501010	1	TRIGGER
35	403222	1	SEAL,DRIVER BLADE	71	501009	1	ROLL PIN
36	402706	1	FLANGE	72	402669	1	PIN TRIGGER
37	091545	4	S.H.C.S. 1/4-20 X 7/8	74	501023	1	GRIP HANDLE
38	403716	2	S.H.C.S. 10-32 X 5/16	75	004502	4	S.H.C.S. 10-32 X 5/8
39	402738	1	SPRING	76	403217	1	EXTENSION SPRING,FOLLOWER
.				77	501320	1	GUIDE BLOCK
.							
.							

* Denotes normal wear items.

** Make sure warning label (500457) is properly affixed. Replace if necessary. Label available at no charge through the Service Dept.

▲ Apply Loctite 242 (Blue) Part No. 093500

→ Denotes new change.

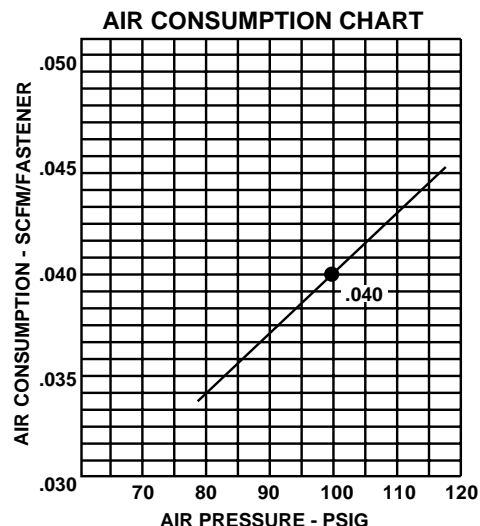

ACCESSORIES

Sequential Operating Kit

This special attachment is designed for sequential operation (stops "contact firing"). The operator must depress and hold the work contacting element against the work surface before pulling the trigger. This sequence must be repeated each time the tool drives a fastener.

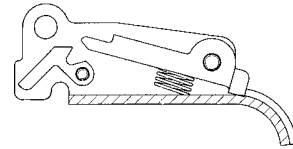

Part No. 501039

Remote Fire Valve

This valve via a positive air signal allows a machine mounted tool to be operated from an automatic air valve or foot pedal system.

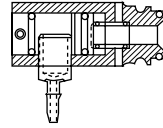

Part No. 1x0713

Trigger Valve Repair Kit

This kit repairs all trigger valve air leaks.

Part No. 219224

"O"Ring Kit

This kit repairs all air leaks.

Part No.

Lubricants

→ Lubricating Oil 16 oz.

Part No. F27625

Degreaser Cleaner

Ideal Cleaner for all Paslode Tools

Part No. B20544L

Belt Hook Holder

Attaches to work belt and carries tool using the above belt hook

Part No. 219028

SAFETY INSTRUCTIONS

WEAR EYE AND HEARING PROTECTION



Always wear hearing protection and eye protection devices, including side shields when operating or working in the vicinity of a tool.



Never use any bottled air or gases such as oxygen to operate the tool since they could cause the tool to explode.

DO NOT EXCEED MAXIMUM RECOMMENDED AIR PRESSURE

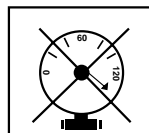

Operate the tool using only the recommended air pressure. Do not exceed the maximum air pressure marked on the tool. Be sure the air pressure gauge is operating properly and check it at least twice a day.

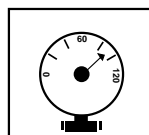

An Illinois Tool Works Company
888 Forest Edge Drive
Vernon Hills, Illinois 60061