

ESP 8	MACHINE CODE A00903	DESC. P1B 80-16
----------	------------------------	--------------------

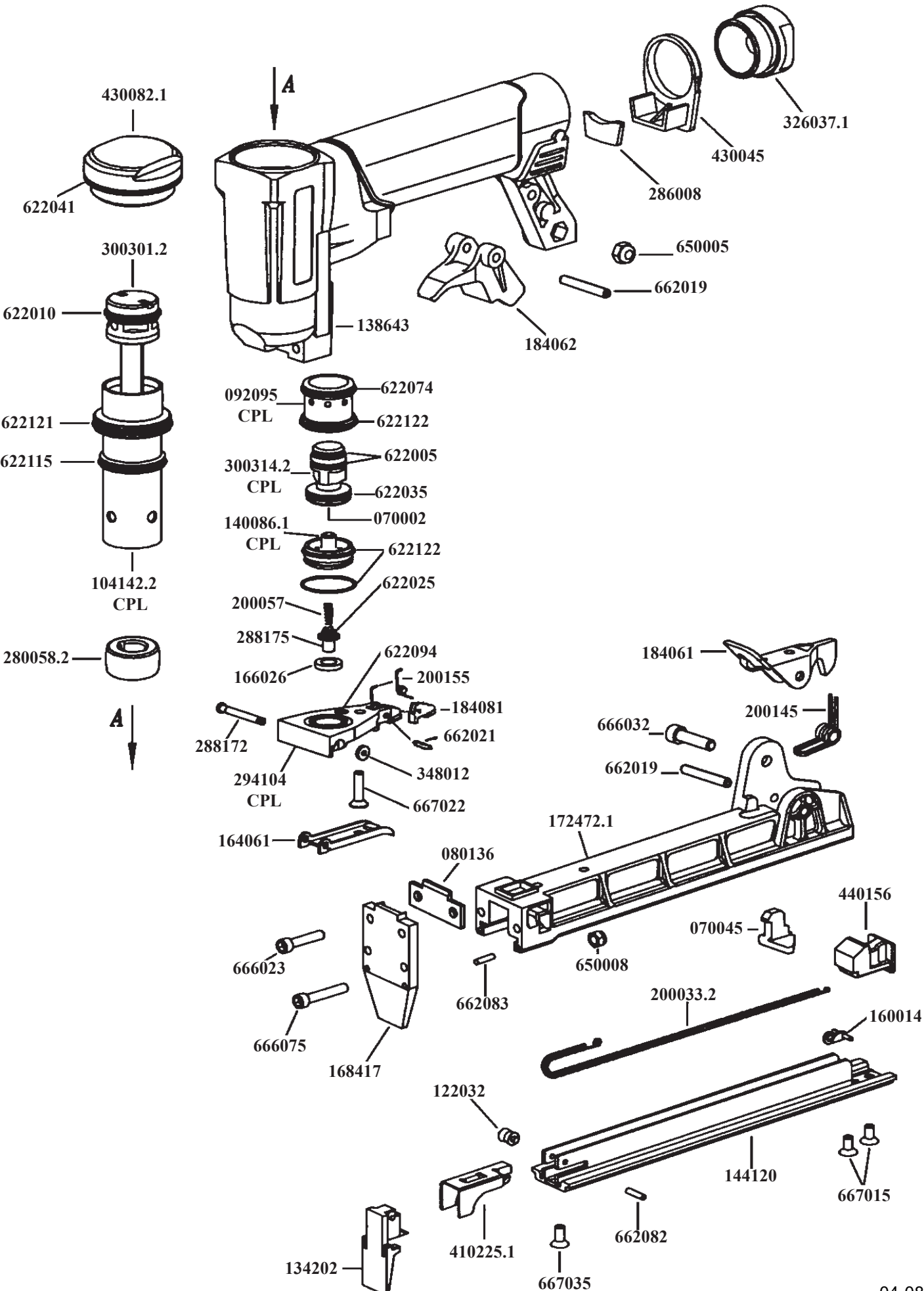

MACHINE CODE**A00903****MODEL****P1B 80-16****PARTS LIST**

CODE	QTY	DESCRIPTION	CODE	QTY	DESCRIPTION
070002	R 1	BUFFER	650005	R 1	NUT
070045	R 1	BUFFER	650008	R 2	NUT
080136	1	REST	662019	R 2	PIN
092095	1	CPL BUSH	662021	R 1	PIN
> 104142.2	1	CPL CYLINDER	662082	R 4	PIN
122032	1	PULLEY	662083	R 2	PIN
134202	1	NOSE RAIL	666023	R 2	SCREW
138643	1	BODY	666032	R 1	SCREW
140086.1	1	VALVE	666075	R 2	SCREW
144120	1	SLIDER	667015	R 2	SCREW
160014	1	HOOK	667022	R 1	SCREW
164061	1	TRIGGER	667035	R 1	SCREW
166026	1	GASKET			
168417	1	DRIVER PLATE			
> 172472.1	1	LOADER			
184061	1	CATCH			
184062	1	CATCH			
184081	1	TRIGGER LEVER W/THUMB SAFETY			
200033.2	1	SPRING			
200057	1	SPRING			
200145	1	SPRING			
200155	1	SPRING			
280058.2	1	BUMPER			
286008	1	MUFFLER			
288172	1	PIN			
288175	1	PIN			
294104	1	CPL PLATE			
300301.2	1	CPL DRIVER/PISTON			
> 300314.2	1	CPL VALVE PISTON			
> 326037.1	1	ADAPTER 1/4"			
348012	1	STOP RING			
410225.1	1	PUSHER			
430045	1	COVER			
430082.1	1	CAP			
440156	1	CATCH SLOT			
622005	R 2	O-RING			
622010	R 1	O-RING			
622025	R 1	O-RING			
622035	R 1	O-RING			
622041	R 1	O-RING			
622074	R 1	O-RING			
622094	R 1	O-RING			
622115	R 1	O-RING			
622121	R 1	O-RING			
622122	R 3	O-RING			

R = RECOMMENDED SPARE PARTS

> = DENOTES NEW CHANGE