

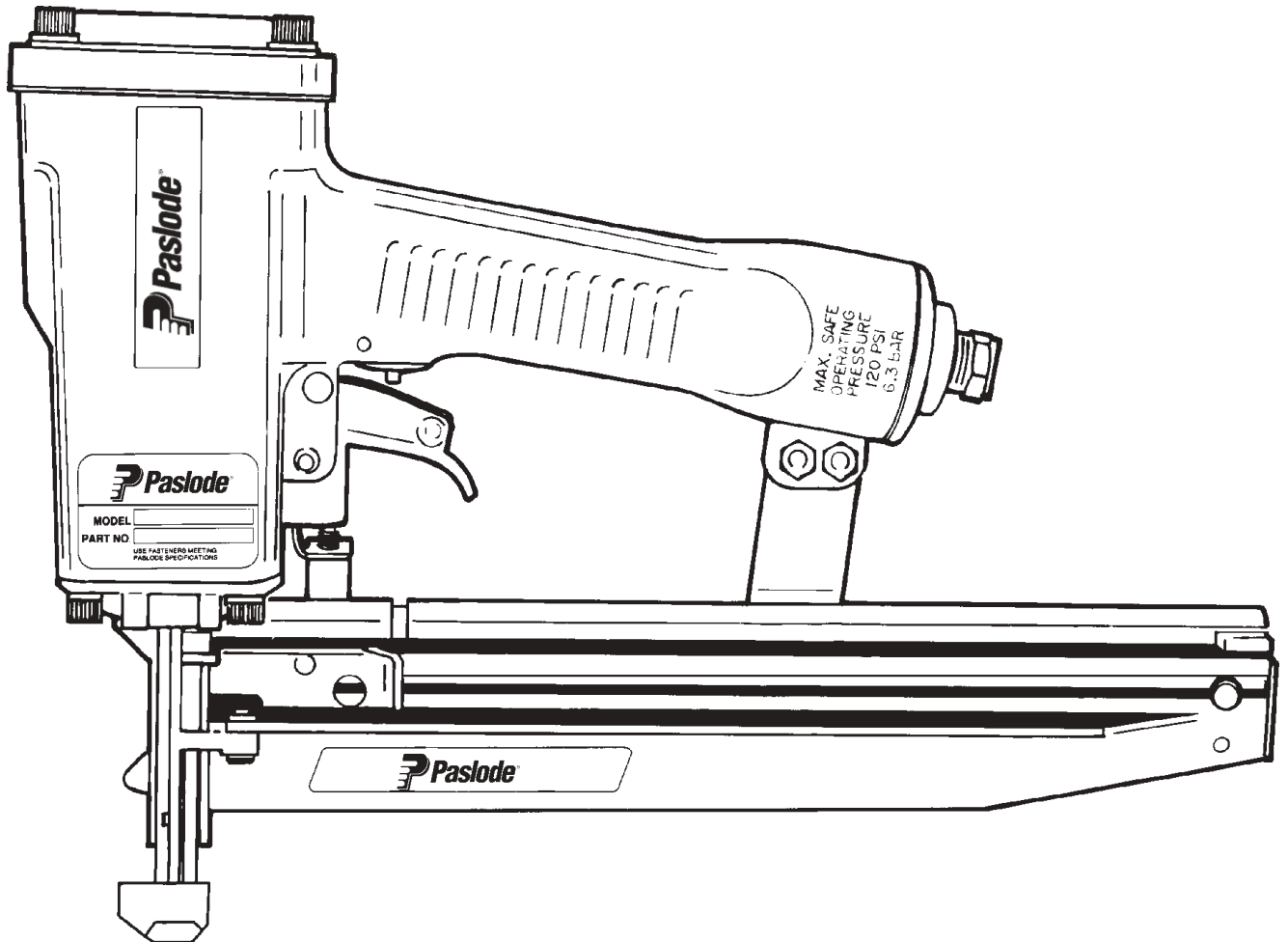

MODEL 3250-F16
FINISH NAILER



TOOL SCHEMATIC AND PARTS

IMPORTANT! **DO NOT DESTROY**

Always refer to safety and maintenance manual #403606 for detailed information on this tool. It is the customer's responsibility to have all operators and service personnel read and understand this information.

3250-F16
403700

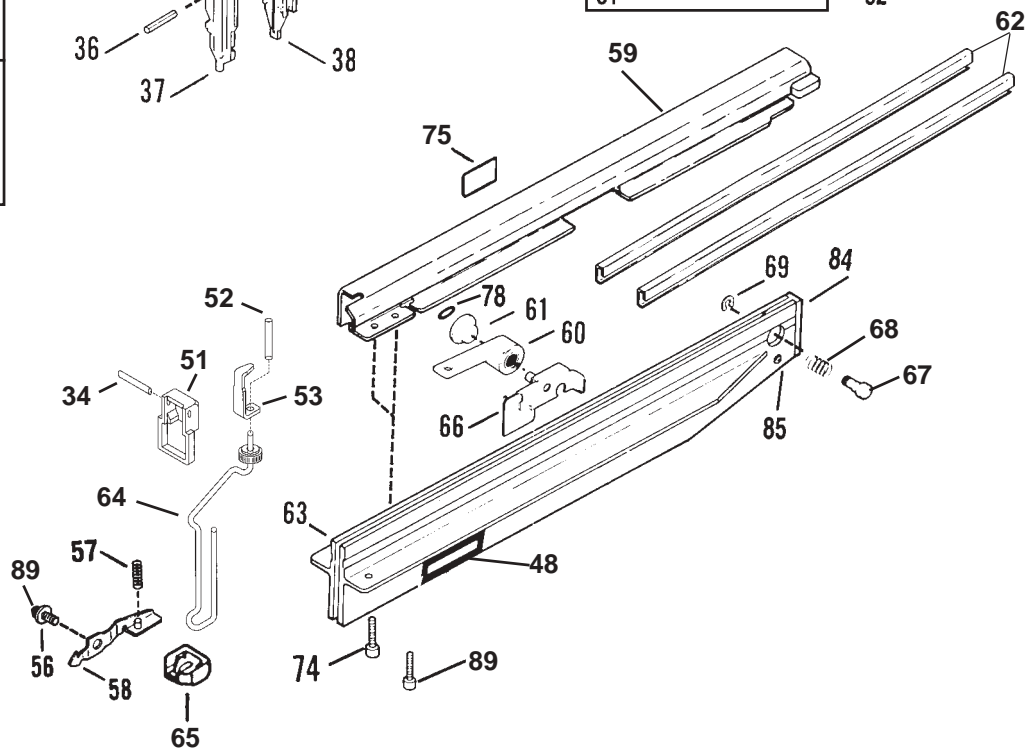
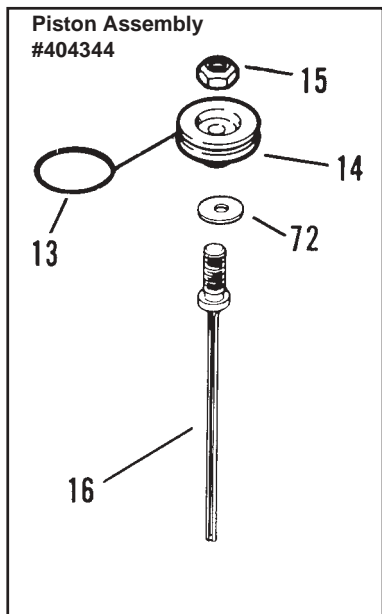
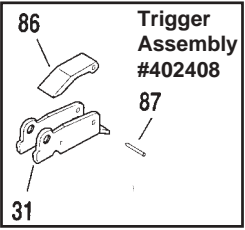
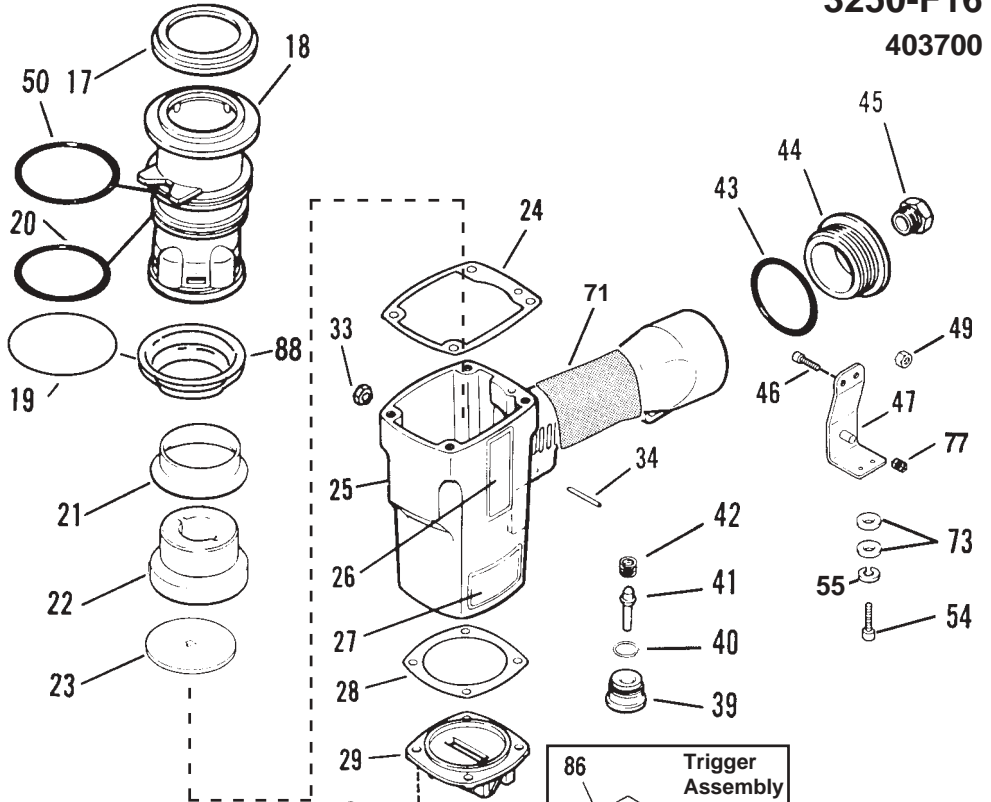
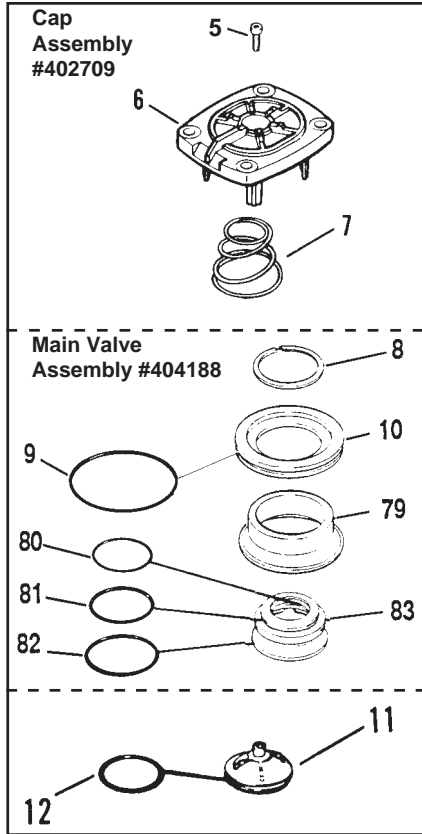
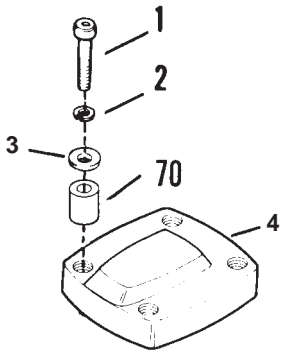

⚠ WARNING
All parts must be periodically inspected and replaced if worn or broken. Failure to do this can affect the tool's operation and present a safety hazard.

PARTS LEGEND 3250-F16, 403700

1	091362	4	Socket Head Capscrew, 1/4-20 x 1-1/2"	45	091622	1	Reducing Pipe Bushing
2	002187	4	Lock Washer, 1/4"	46	004502	2	Socket Head Capscrew, #10-32 x 5/8"
3	091447	4	Flat Washer	47	403746	1	Rail Bracket Assembly
4	404242	1	Cap, Diffuser	48	402731	1	Logo-Rail
5	006310	1	Socket Head Capscrew, #6-32 x 1/2"	49	092037	2	Lock Nut, #10 - 32
6	402704	1	Cap	50	091966	1	O-Ring, Sleeve
7	402717	1	Conical Spring	→ 51	500766	1	Guide Block
8	404230	1	Retaining Ring	→*52	500772	1	Spring, Work Contacting Element
*9	091537	1	"O" Ring, Main Valve Assembly	→ 53	500768	1	Intermediate Work Contacting Element
10	404122	1	Upper Valve Piston	→ 54	004224	2	Socket Head Capscrew, #10 - 32 x 3/8"
11	404055	1	Post, Main Valve	55	004238	2	Lock Washer #10
*12	404256	1	"O" Ring, Main Valve Post	56	402629	1	Hardened Washer
*13	402723	1	"O" Ring, Piston	57	405076	1	Spring
14	403563	1	Piston	58	403712	1	Front Guide Latch Assembly
15	403582	1	Jam Nut	59	403724	1	Rail Cover Assembly
*16	403594	1	Driver Blade	60	403708	1	Negator Assembly
17	402725	1	Seal, Sleeve	61	403710	1	Roller, Negator
18	405245	1	Sleeve	62	403702	2	Wear Strip
*19	402728	1	"O" Ring, Flange	63	403745	1	Rail Assembly
*20	402729	1	"O" Ring, Sleeve	→ 64	500840	1	Work Contacting Element Assembly
21	403854	1	Retaining Bumper	65	404180	1	Tip, Deep Drive (Black)
*22	403853	1	Bumper	66	403715	1	Follower Assembly
23	403705	1	Seal, Driver Blade	67	403711	1	Latch Pin, Follower
*24	402707	1	Gasket, Cap	68	091536	1	Spring, Follower Latch Pin
25	402701	1	Housing	69	403713	1	Retaining Ring
26	404939	2	Logo, Housing	70	404243	4	Spacer
→ 27	500883	1	Nameplate	71	500488	1	Grip, Handle
28	402708	1	Gasket, Flange	72	404274	1	Washer
29	402706	1	Flange	73	403812	2	Flat Washer
30	091545	4	Socket Head Capscrew, 1/4-20 x 7/8"	74	009397	2	Capscrew #10-24 x 1/2"
31	405144	1	Trigger	**75	500458	1	Warning Label
32	402079	1	Pin, Trigger	77	401988	1	Spring, Front Guide Latch
33	404325	1	Stop Nut	78	094295	1	"O" Ring
34	026133	2	Roll Pin, 1/8" Dia. x 1" Lg.	79	404054	1	Seal, Main Valve
35	402730	1	Pivot Pin, Front Guide	*80	090927	1	"O" Ring, Main Valve
36	404698	2	Roll Pin, Assembly	*81	092775	1	"O" Ring, Main Valve
37	403592	1	Front Guide	*82	092773	1	"O" Ring, Main Valve
38	403591	1	Back Plate	83	404056	1	Lower Valve Piston
39	401958	1	Valve Body	84	403599	1	Spacer
*40	092174	1	"O" Ring, Valve Body	85	403731	1	Rivet
41	097746	1	Valve Pin	86	405147	1	Lever, Trigger
42	097748	1	Spring, Valve Pin	87	005849	1	Roll Pin
*43	091591	1	"O" Ring, End Plug	88	405243	1	Flange, Sleeve
44	401940	1	End Plug	89	403716	3	Socket Head Capscrew 10-32 x 5/16"

* Denotes normal wear items

** Make sure Warning Label (500458) is properly affixed.
Replace if necessary. Label available at no charge through Service Department.

▲ Apply Loctite 242 (Blue)

→ Denotes New Change

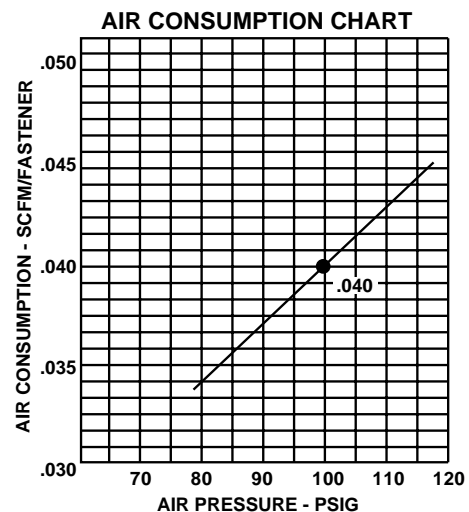

ACCESSORIES

Sequential Operating Kit

This special attachment is designed for sequential operation ("stops contact firing"). The operator must depress and hold the work contacting element against the work surface before pulling the trigger. This sequence must be repeated each time the tool drives a fastener.

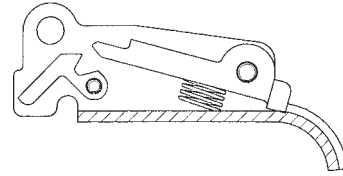

Part No. 406006

Remote Fire Valve

This valve via a positive air signal allows a machine mounted tool to be operated from an automatic air valve or foot pedal system.

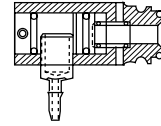

Part No. 1x0713

Lubricants and Loctite

Chemplex 710 Lubricant 1 lb. Part No. 403734
 Lubricating Oil 8 oz. Part No. 219026
 Lubricating Oil with Antifreeze Part No. 219090
 Loctite 242 (Blue) 1 oz. Part No. 093500

Safety Glasses

Clear Part No. 402510
 Tinted Part No. 402512

Back Plate Insert

This insert accommodates 1 1/4" and shorter finish nails. Also prevents nails from tumbling and jamming. Part No. 1X1210

Degreaser Cleaner

Ideal cleaner for all Paslode tools. Part No. 219086

Universal Belt Hook

Attaches to cap of tool enabling you to carry tool on belt holder (offered below). Part No. 219017

Finish Nailer Repair Kit

This kit repairs all air leaks except for the trigger valve. Part No. 219221

Belt Hook Holder

Attaches to work belt and carries tool using the above belt hook. Part No. 219028

Trigger Valve Repair Kit

This kit repairs trigger valve air leaks. Part No. 219224

SAFETY INSTRUCTIONS

WEAR EYE AND HEARING PROTECTION



Always wear hearing protection and eye protection devices, including side shields when operating or working in the vicinity of a tool.



Never use any bottled air or gases such as oxygen to operate the tool since they could cause the tool to explode.

DO NOT EXCEED MAXIMUM RECOMMENDED AIR PRESSURE

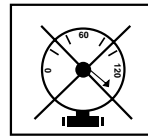

Operate the tool using only the recommended air pressure. Do not exceed the maximum air pressure marked on the tool. Be sure the air pressure gauge is operating properly and check it at least twice a day.

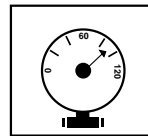

An Illinois Tool Works Company
 888 Forest Edge Dr.
 Vernon Hills, Illinois 60061