

MACHINE CODE : B20574

Model: IM250 II

Part No. 900400

Impulse 16 Gauge Finish Nailer

**MODEL IM250 F-16 II
IMPULSE FINISH NAILER**

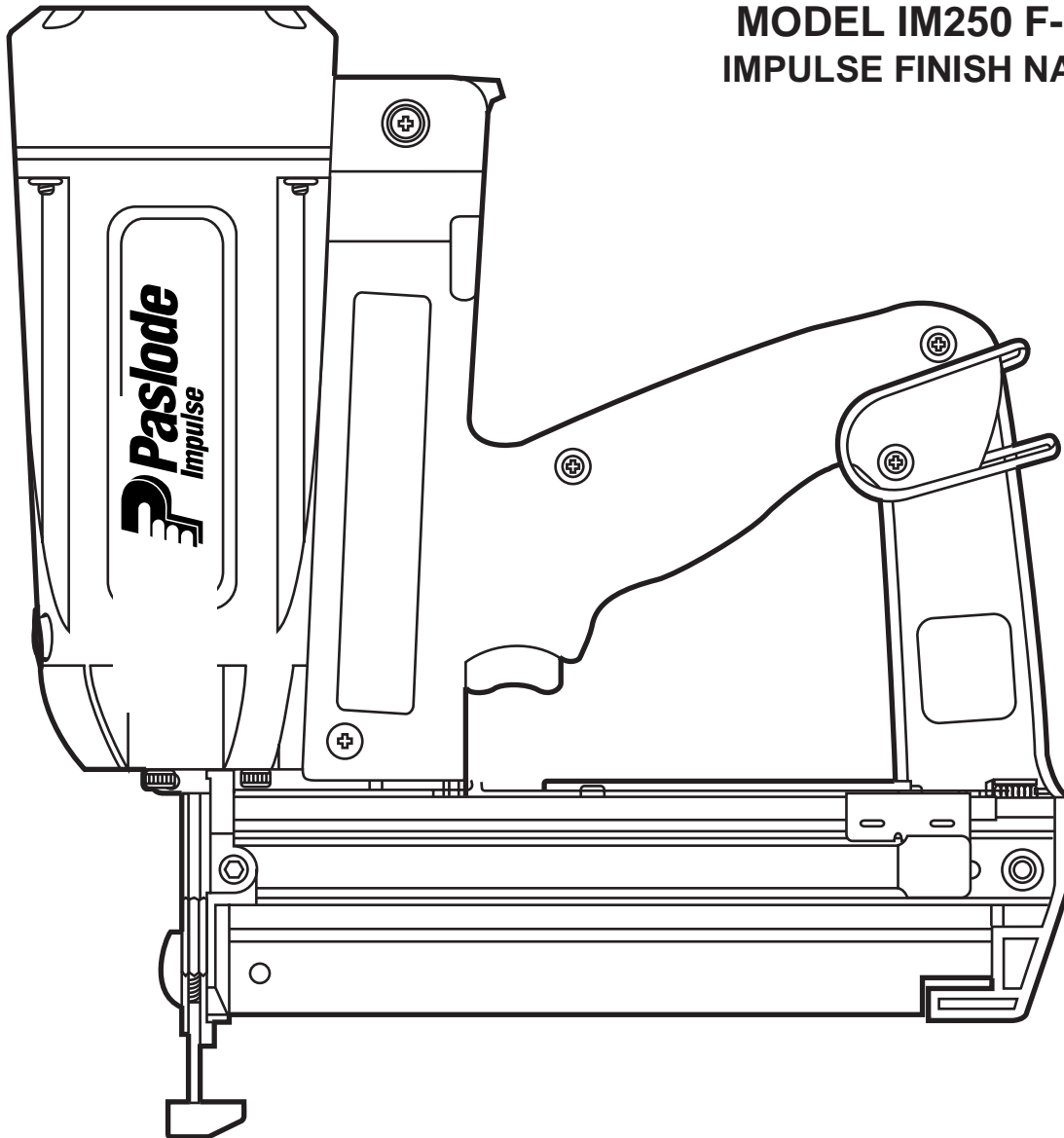

TOOL SCHEMATIC AND PARTS

**IMPORTANT!
DO NOT DESTROY**

Always refer to operators manual #405606 for detailed information on this tool. It is the customers responsibility to have all operators and service personnel read and understand this information.

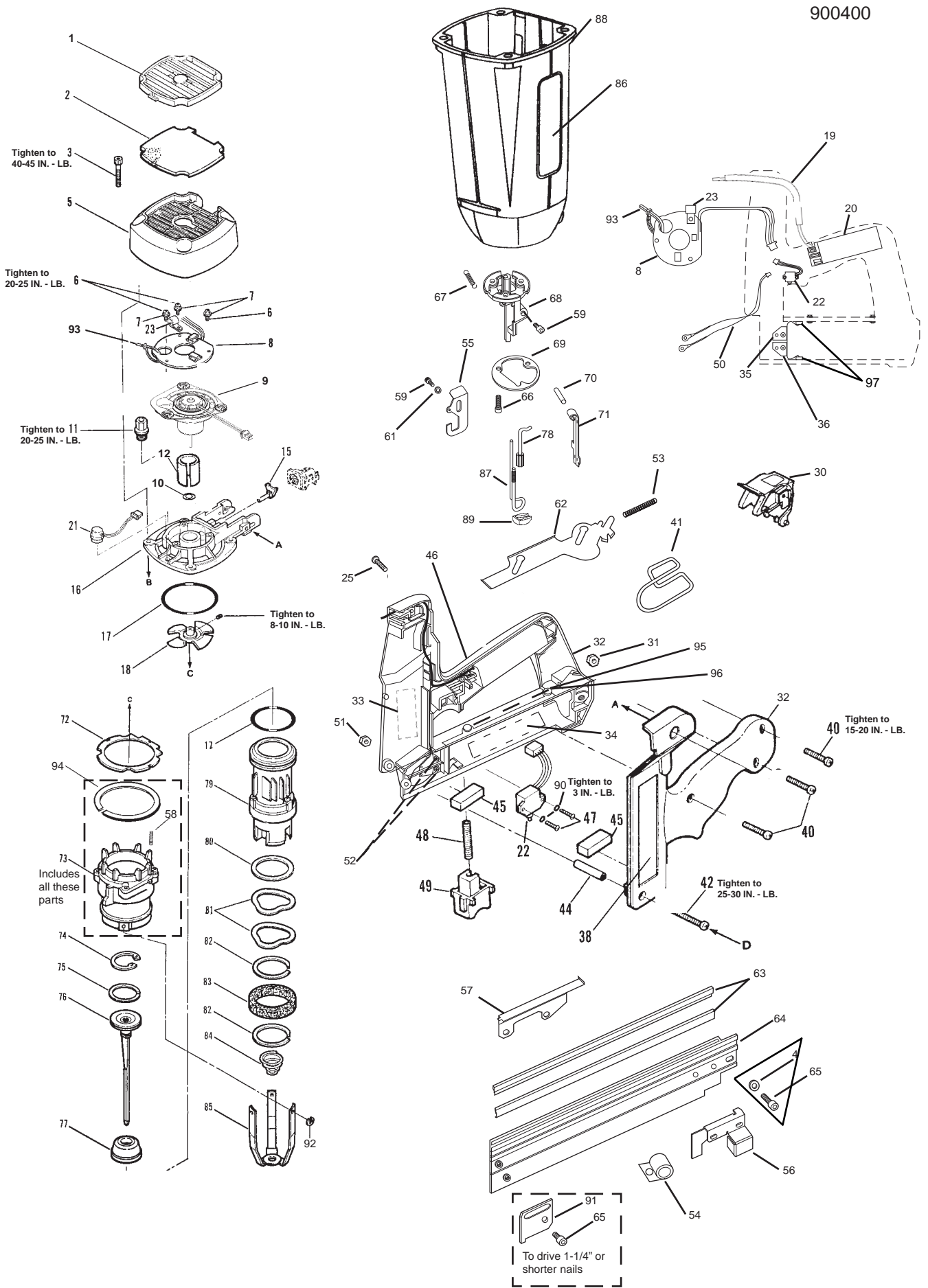

03 MODEL

MACHINE CODE : B20574

PARTS LEGEND

IM250 F-16 TYPE II, 900400

1	900356	1	Grille	53	900329	1	Spring, Cover	
2	900455	1	Filter	54	900328	1	Spring, Negator	
3	901065	4	Shoulder Screw, 10-24 x 1-1/4	55	900350	1	Lever, Quick Clear	
4	008388	1	Flat Washer #10	56	900301	1	Follower	
>	5	900960	1	Cap Assembly	57	900302	1	Cover
>	6	900969	3	Screw, Taptime, B-32 x 5/8	58	900166	1	Spring
7	006562	3	Washer #8	▲	59	900338	2	Screw 10-32 x 1/2
8	900271	1	Circuit Board Assembly	61	900332	1	Hub	
9	900573	1	Fan Motor with Mount	62	900303	1	Cover, Moveable	
10	900468	1	Washer	63	900326	2	Wear Strip	
11	900287	1	Spark Plug Assembly	64	900417	1	Rail Assembly	
12	401356	1	Sleeve, Motor	65	900900	2	Socket Head Cap Screw 10-32 x 5/16	
15	403146	1	Stem Adapter (Yellow)	▲	66	004174	3	Screw 10-24 x 7/8
16	900004	1	Cylinder Head	67	900335	1	Spring, Quick Clear	
*17	404700	2	O-Ring	68	900412	1	Nose Assembly	
18	403167	1	Fan Blade Assembly	69	900342	1	Mounting Ring	
19	900479	1	Removable spark Plug Wire	70	900353	1	Pivot Pin	
20	900280	1	Spark Unit Assembly	71	900324	1	Front Guide	
21	404601	1	Head Switch Assembly	72	403104	1	Air Dam	
22	404490	1	Trigger Switch Assembly	73	403100	1	Combustion Chamber Assembly	
23	900232	1	Cable Clamp	74	403099	1	Retaining Ring, Piston	
25	900968	2	Screw 10-32 x 5/8	*75	403098	1	Piston Ring	
30	900415	1	Actuator Assembly	76	403095	1	Piston Driver Blade Assembly	
31	900405	1	Self Clenching Nut	*77	403094	1	Bumper	
→	32	900944	1	Handle Assembly, Right	78	900416	1	Upper Probe Assembly
**33	900496	1	Warning label	79	403084	1	Sleeve and Midcheck Ring Assembly	
34	900576	1	Nameplate	80	403089	1	Seal Washer	
35	900312	1	Contact Positive	81	403090	2	Wave Washer	
36	900311	1	Contact Negative	82	403092	2	Retaining Ring, Midcheck	
→	37	900943	1	Handle Assembly, Left	83	403091	1	Muffler
38	900508	1	International Label	84	404339	1	Spring, Chamber Return	
40	900453	3	Thread Forming Screw, 8-16 x 7/8	85	403106	1	Cage	
41	900289	1	Belt Hook	86	900651	2	Label, Logo	
42	900903	1	Screw, 8-32 x 1 1/2	87	900323	1	Probe, Lower	
43	403082		REMOVED	88	900411	1	Housing Assembly	
44	900942	1	Bushing (SILVER)	89	900352	1	Tip	
45	401450	2	Pad	90	900182	2	Washer, Trigger	
46	404385	1	Light Pipe	91	B20579A	1	Back Plate Insert	
47	402201	2	Screw, Phillips Head, 2-56 x 5/8	92	403713	3	E-Ring, Retaining	
48	401395	1	Spring	93	404613	1	Cable Tie	
49	900358	1	Trigger	94	900164	1	Ring	
50	900336	1	Contact Wire Assembly	95	900331	2	Insert, Handle	
51	900941	1	Nut 8-32	96	900341	2	E-Ring	
52	404702	2	Screw, Thread 6-32 x 3/8	97	404922	2	Battery Pad	

* Denotes Normal Wear Item.

▲ Apply Loctite 242 (Blue) Part No.093500

** Make sure Warning Label (900496) is properly affixed replace if necessary. Label is available at no charge through the Service Dept.

→ Denotes Change

SAFETY INSTRUCTIONS

1. WEAR EYE AND EAR PROTECTION.
2. ALWAYS ASSUME THE TOOL IS 'LOADED'.
3. OPERATE THE TOOL ONLY ON THE WORK SURFACE.
4. NEVER REMOVE OR DISABLE THE WORK CONTACTING ELEMENT.
This device helps reduce the possibility of accidental fastener discharge by preventing the tool from operating until it is completely against the work surface. NEVER operate the tool if the work contacting element is not working properly.
5. ALWAYS POINT THE TOOL AWAY FROM YOURSELF AND OTHERS WHEN CLEARING JAMS OR REMOVING FASTENERS.
Pull the follower back and latch. Tip the tool nose up slightly and fasteners should slide out of the magazine. If fasteners are jammed, refer to the appropriate section of the operating manual.
6. NEVER ATTEMPT TO OPERATE THE IMPULSE TOOL IF PARTS ARE LOOSE, DAMAGED OR MISSING.

ACCESSORIES

Impulse Nailer Case

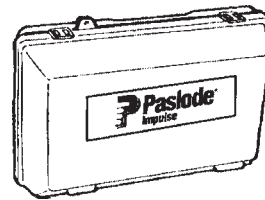

Part No. 900488

Battery Cell



Part No. B20544E

Impulse Oil



Part No. B20544F

Torx Key

For tightening fan blade to motor

Part No. 900183

Battery Charger Kit

(Replacement Transformer Only Part No. B20544C)



Part No. B20544B

ND NOSE PLATE

TO SHOOT ND-BRADS

Part No. B20579

Degreaser Cleaner

Ideal cleaner for all Paslode tools



Part No. B20544L



An Illinois Tool Works Company
888 Forest Edge Drive
Vernon Hills, Illinois 60061